

NOTES:

1. SUBSTRATE MATERIAL:  
N-BK7

2. COATING:

S1, S2, & S3: PROTECTED SILVER  
R(avg) >98% @ 500 - 800nm  
R(avg) >98% @ 2 - 10µm W/BLACK OVERPAINT

3. RAY DEVIATION: 180°

4. RoHS COMPLIANT

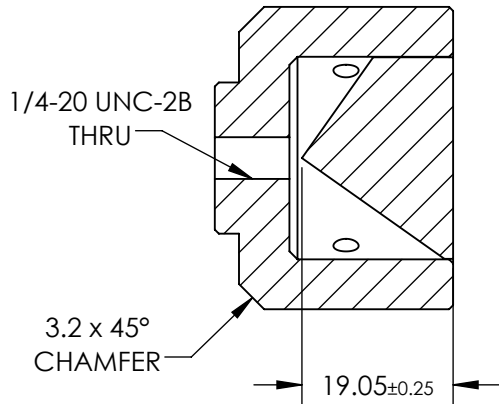
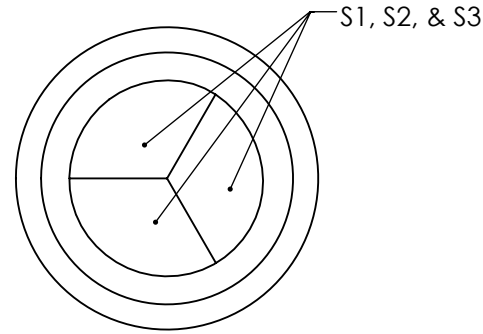

SECTION A-A

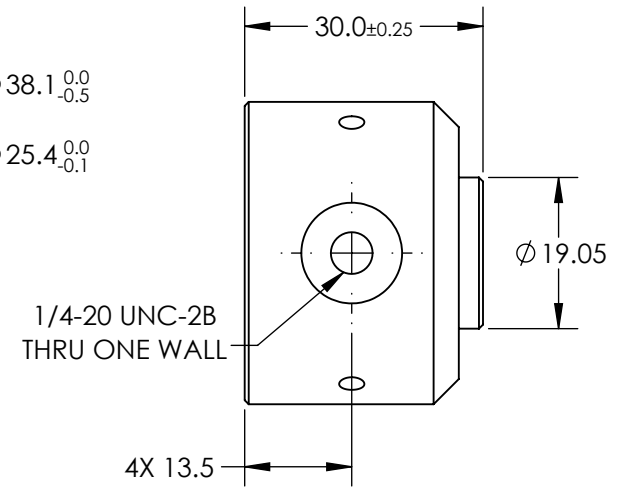
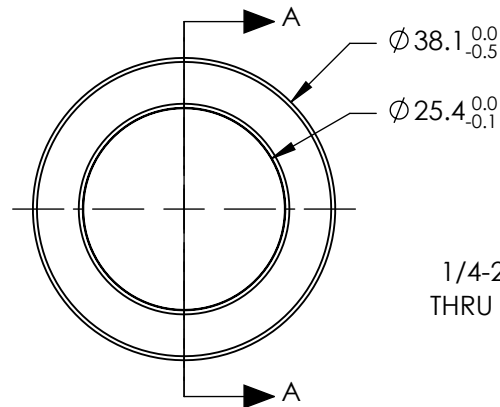

**FOR INFORMATION ONLY:  
DO NOT MANUFACTURE  
PARTS TO THIS DRAWING**

SPECIFICATIONS SUBJECT TO CHANGE WITHOUT NOTICE  
DIMENSIONS ARE FOR REFERENCE ONLY

REV. A	S1	S2	S3
SHAPE	PLANO	PLANO	PLANO
SURFACE QUALITY	60-40	60-40	60-40
WAVELENGTH RANGE (nm)	500 - 10000	500 - 10000	500 - 10000
BEVEL	PROTECTED AS NEEDED	PROTECTED AS NEEDED	PROTECTED AS NEEDED



ALL DIMS IN

mm

**EO**® Edmund Optics®

TITLE

PRISM CORNER CUBE 25.4mm MTD

DWG NO

45188

SHEET  
1 OF 1