

NOTES:

1. SUBSTRATE

FUSED SILICA

2. SURFACE S2 TO BE PARALLEL WITH S1 WITHIN < 3 ARCMIN

3. COATING (APPLY ACROSS CLEAR APERTURE)

S1: ND:YAG LASER

R(abs) >99% @ 635 - 670 & 1064nm @ 45° AOI

DAMAGE THRESHOLD: 20 J/cm² @ 20ns

S2: NONE

4. FINE GROUND SURFACE

5. POWER, IRREGULARITY, SURFACE QUALITY, AND COATING SPECIFICATIONS APPLY ACROSS CLEAR APERTURE

6. RoHS COMPLIANT

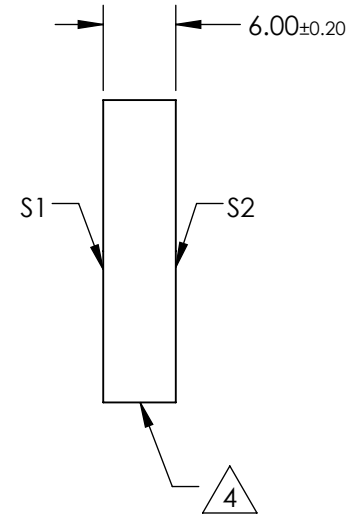
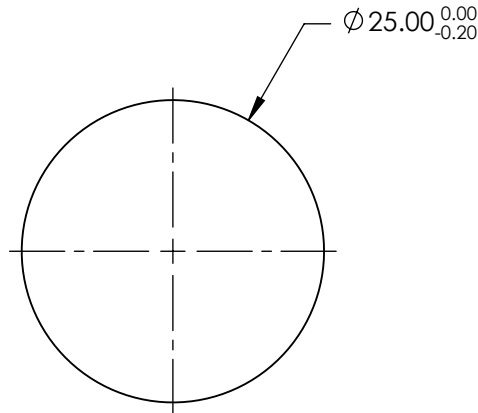
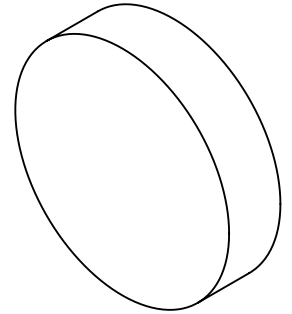

**FOR INFORMATION ONLY:
DO NOT MANUFACTURE
PARTS TO THIS DRAWING**

SPECIFICATIONS SUBJECT TO CHANGE WITHOUT NOTICE
DIMENSIONS ARE FOR REFERENCE ONLY

REV. A	S1	S2
SHAPE	PLANO	PLANO
SURFACE FLATNESS	$\lambda/10$	N/A
SURFACE QUALITY	10 - 5	FINE GROUND
CLEAR APERTURE	Ø22.5	N/A
BEVEL	PROTECTIVE AS NEEDED	PROTECTIVE AS NEEDED

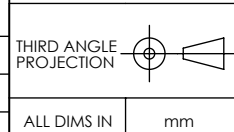

EO® Edmund Optics®

TITLE	Ø25mm, 635-670 & 1064nm, 45°, ND:YAG LASER LINE MIRROR	
DWG NO	47979	SHEET 1 OF 1