

NOTES:

1. SUBSTRATE

FUSED SILICA

2. SURFACE S2 TO BE PARALLEL WITH S1 WITHIN < 3 ARCMIN

3. COATING (APPLY ACROSS CLEAR APERTURE)

S1: Laser Mirror (355nm)  
 R(ABS) >99.5% @ 355nm @ 45° AOI  
 R(AVG) >99.5% @ 351 - 358nm @ 45° AOI

DAMAGE THRESHOLD,  
 PULSED: 6 J/cm² @ 355nm, 20ns, 20Hz  
 CW: 1MW/cm² @ 355nm

S2: NONE

4. FINE GROUND SURFACE

5. POWER, IRREGULARITY, SURFACE QUALITY, AND COATING SPECIFICATIONS APPLY ACROSS CLEAR APERTURE

6. RoHS COMPLIANT

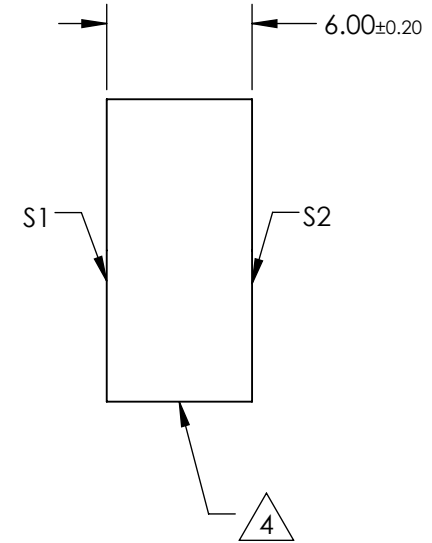
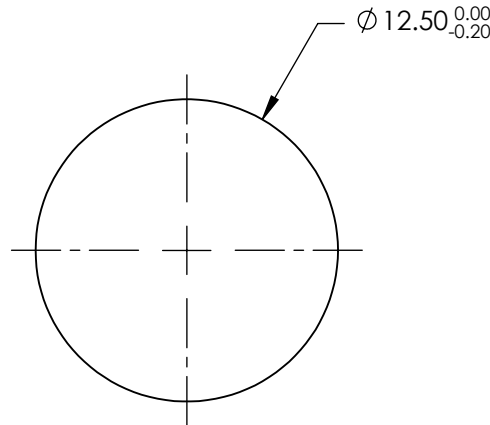
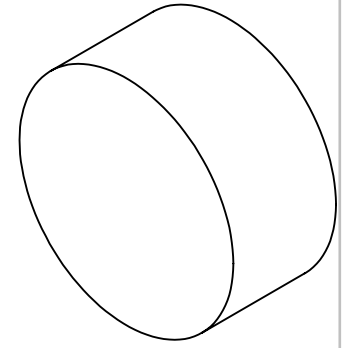

**FOR INFORMATION ONLY:  
 DO NOT MANUFACTURE  
 PARTS TO THIS DRAWING**

SPECIFICATIONS SUBJECT TO CHANGE WITHOUT NOTICE  
 DIMENSIONS ARE FOR REFERENCE ONLY

	S1	S2
SHAPE	PLANO	PLANO
SURFACE FLATNESS	$\lambda/10$	N/A
SURFACE QUALITY	10-5	FINE GROUND
CLEAR APERTURE	Ø11.25	N/A
BEVEL	PROTECTIVE AS NEEDED	PROTECTIVE AS NEEDED

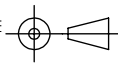
THIRD ANGLE PROJECTION 

ALL DIMS IN mm

**EO**® Edmund Optics®

TITLE	Ø12.5mm, 355nm, 45°, ND:YAG LASER LINE MIRROR		
DWG NO	47323	SHEET 1 OF 1	