

TECHSPEC® 25mm f/8.0, HPi Series Fixed Focal Length Lens

#33-826



25mm HPi Series Lens

TECHSPEC® HPi Series Fixed Focal Length Lenses offer the same high resolution performance as the TECHSPEC HP Series Lenses with a streamlined design. The simplified mechanical design enables a more compact size with a reduction in cost and weight, making them ideal for OEM volume applications. Featuring a wide range of fixed aperture versions and an adjustable focus, TECHSPEC HPi Series Fixed Focal Length Lenses offer the ideal combination of simplicity and flexibility required for industrial applications. Call for OEM Quantity Pricing.

Front Thread:	M27.5 x 0.5 (Female)
Optimized Sensor Format:	1"
Coating:	$\lambda/4$ MgF ₂
Optimized Working Distance (mm):	150 - ∞
Storage Temperature (°C):	-20 to +60 For questions regarding operating temperature please contact our support team

Optical

Horizontal Field of View, 1" Sensor:	86.1mm - 28.4°
Maximum Image Circle (mm):	17.60
Numerical Aperture NA, Object Side:	0.0087
Horizontal Field of View @ Max Sensor Format:	95.9mm - 31.3°
Horizontal Field of View, 1.1" Sensor:	95.9mm - 31.3°
Focal Length FL (mm):	25.00
Primary Magnification PMAG:	0.155
Maximum Sensor Format:	1.1"
Working Distance (mm):	150 - ∞
Aperture (f/#):	f/8.0
Coating Specification:	$\lambda/4$ MgF ₂
Entrance Pupil Position (mm):	28.11
Object Space Principal Plane (mm):	34.43
Image Space Principal Plane (mm):	-13.27
Field of View at Max Sensor Format:	Horizontal: 92.6mm - 31.1° Vertical: 68.8mm - 23.6° Diagonal: 117.3mm - 38.3°
Maximum Distortion (%):	0.919
Exit Pupil Position (mm):	-21.69
Lens Wavelength Range:	VIS

Mechanical

Iris Option:	Fixed
Length (mm):	48.23
Filter Thread:	M34 x 0.50 with required adapter #11-610
Maximum Diameter (mm):	29.2
Weight (g):	57
Maximum Rear Protrusion (mm):	4.48
Number of Elements (Groups):	7 (6)
Mount:	C-Mount

General

Type:	Fixed Focal Length Lens
-------	-------------------------

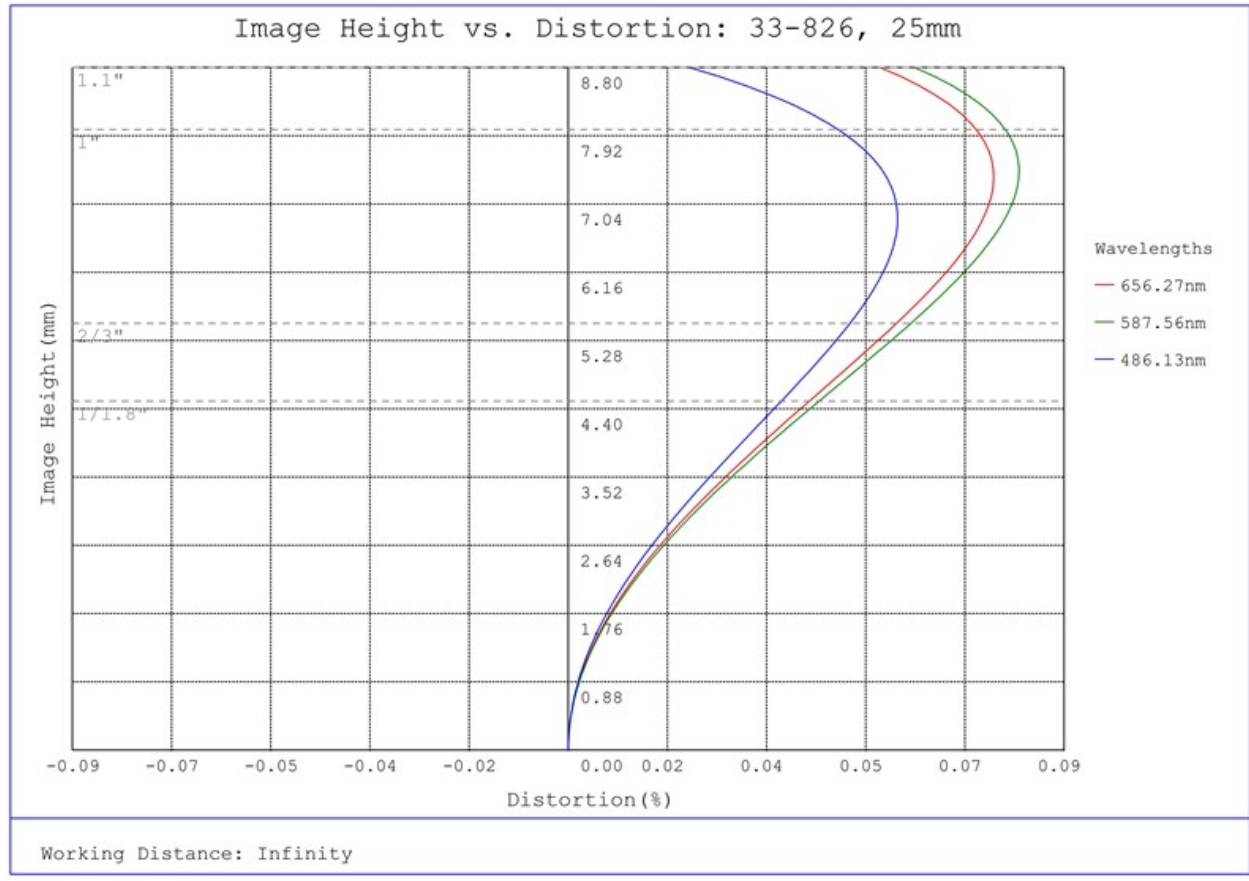

#33-826, 25mm f/8.0, HPI Series Fixed Focal Length Lens, Distortion Plot

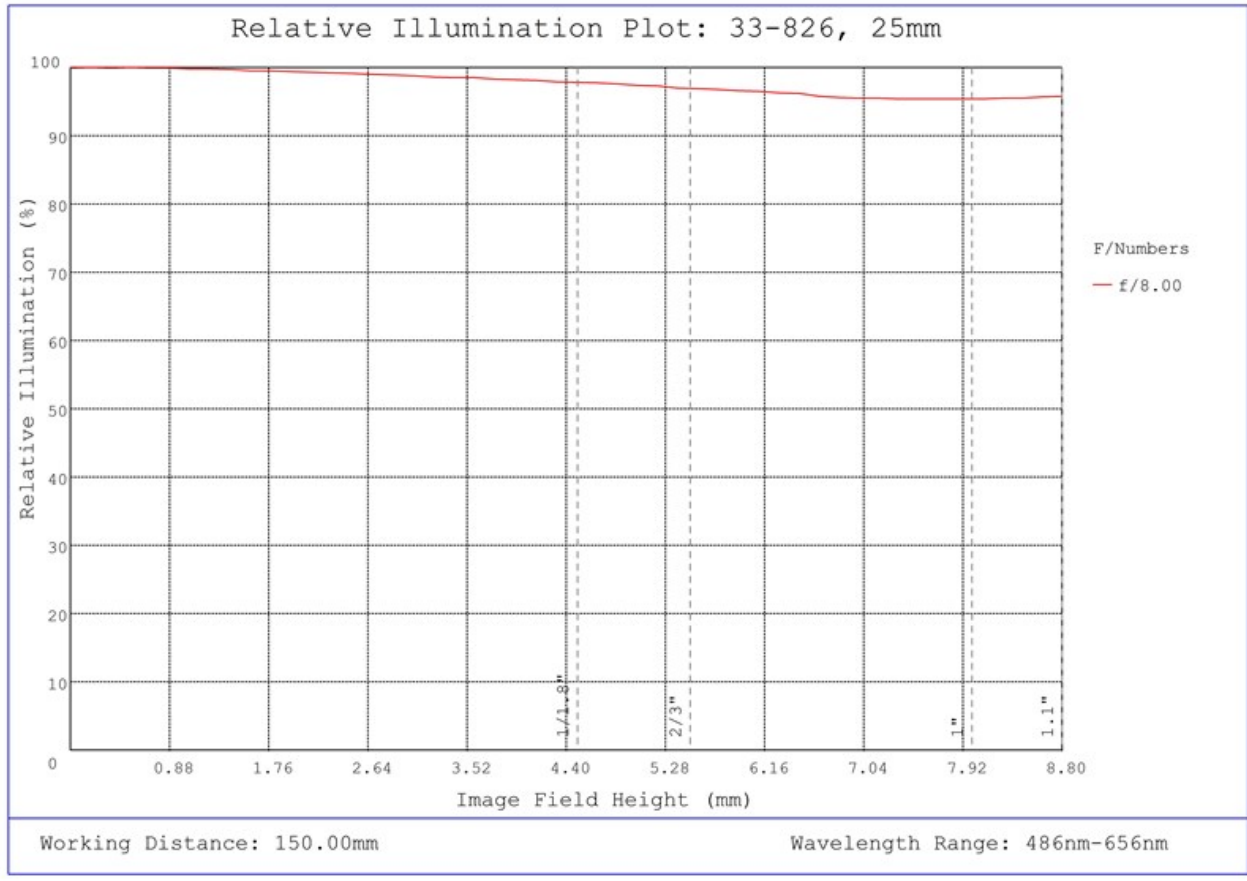

#33-826, 25mm f/8.0, HPi Series Fixed Focal Length Lens, Relative Illumination Plot

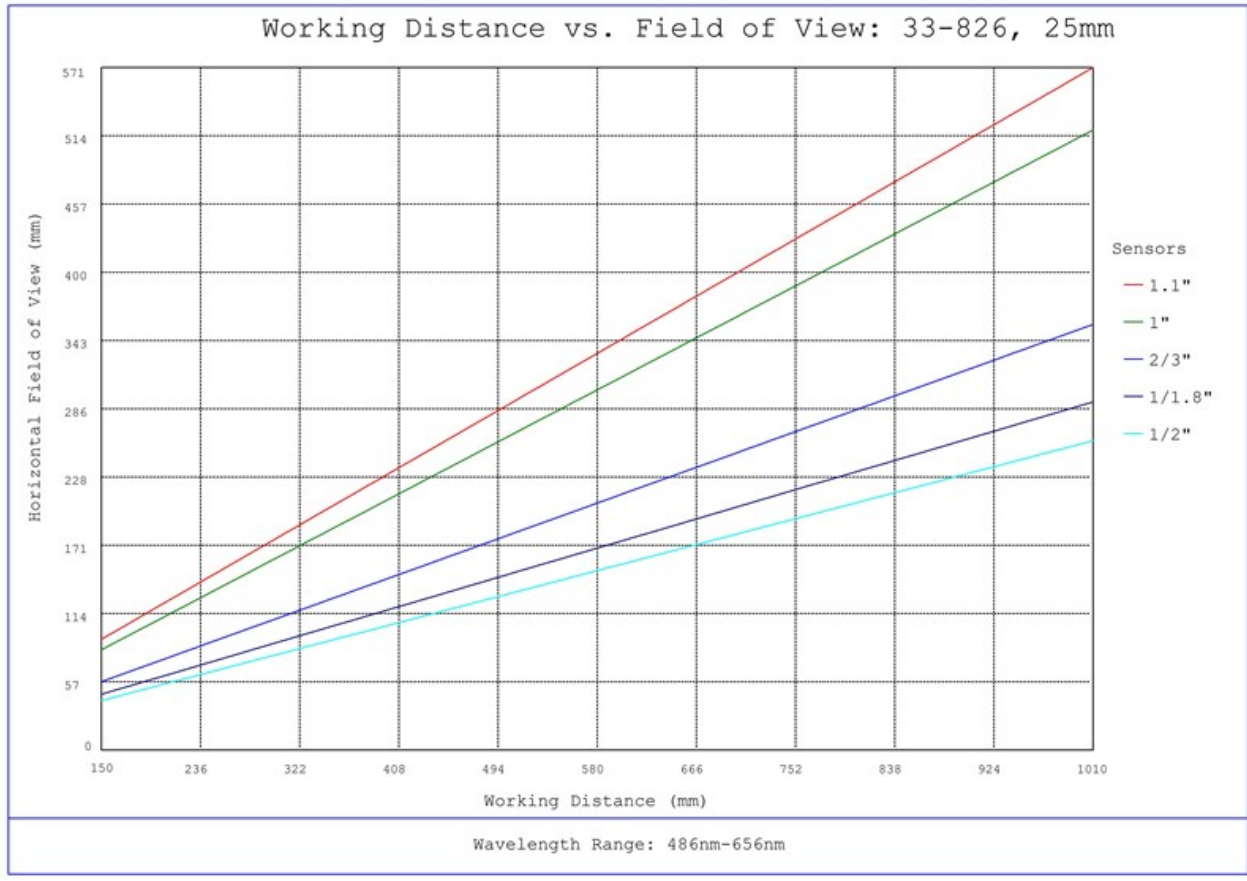

#33-826, 25mm f/8.0, HPi Series Fixed Focal Length Lens, Working Distance versus Field of View Plot

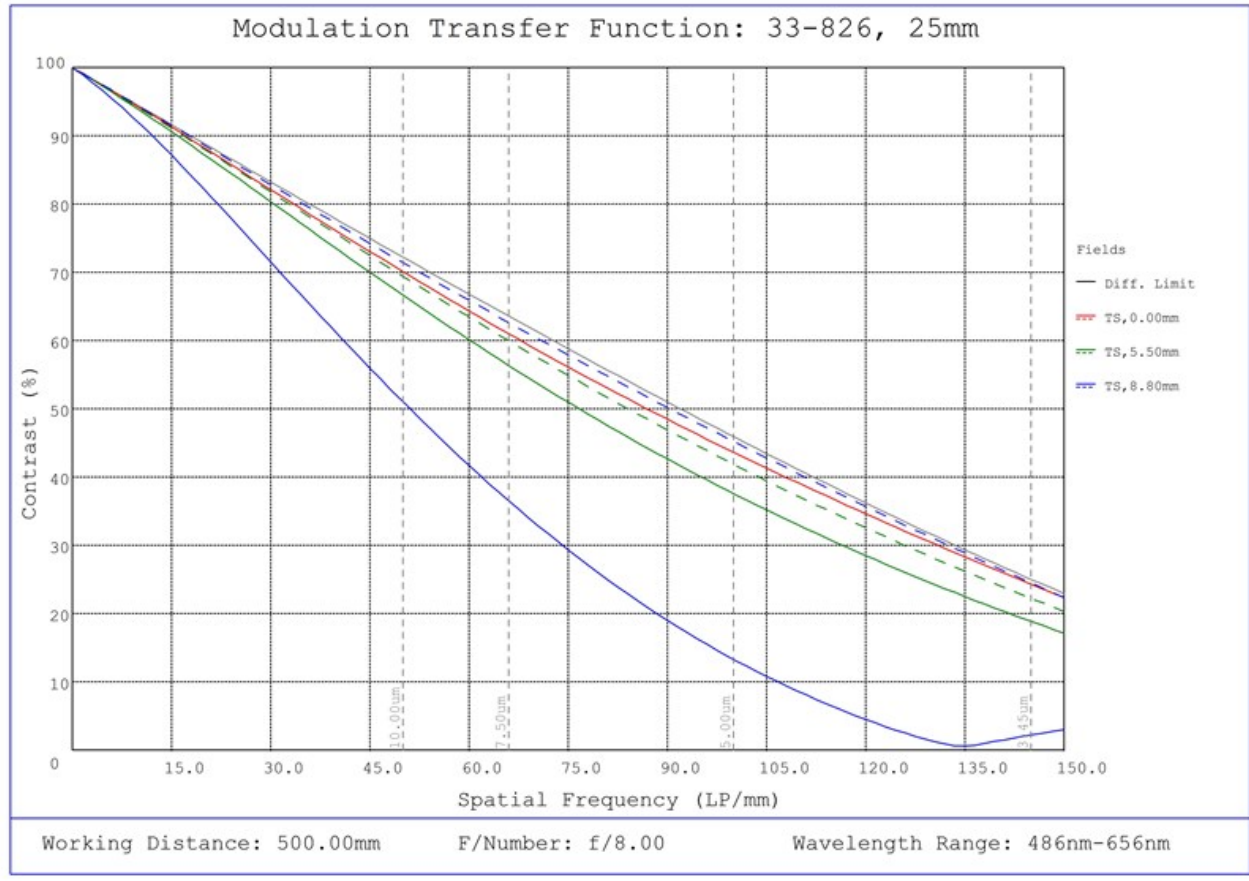

#33-826, 25mm f/8.0, HPi Series Fixed Focal Length Lens, Modulated Transfer Function (MTF) Plot, 500mm Working Distance, f8

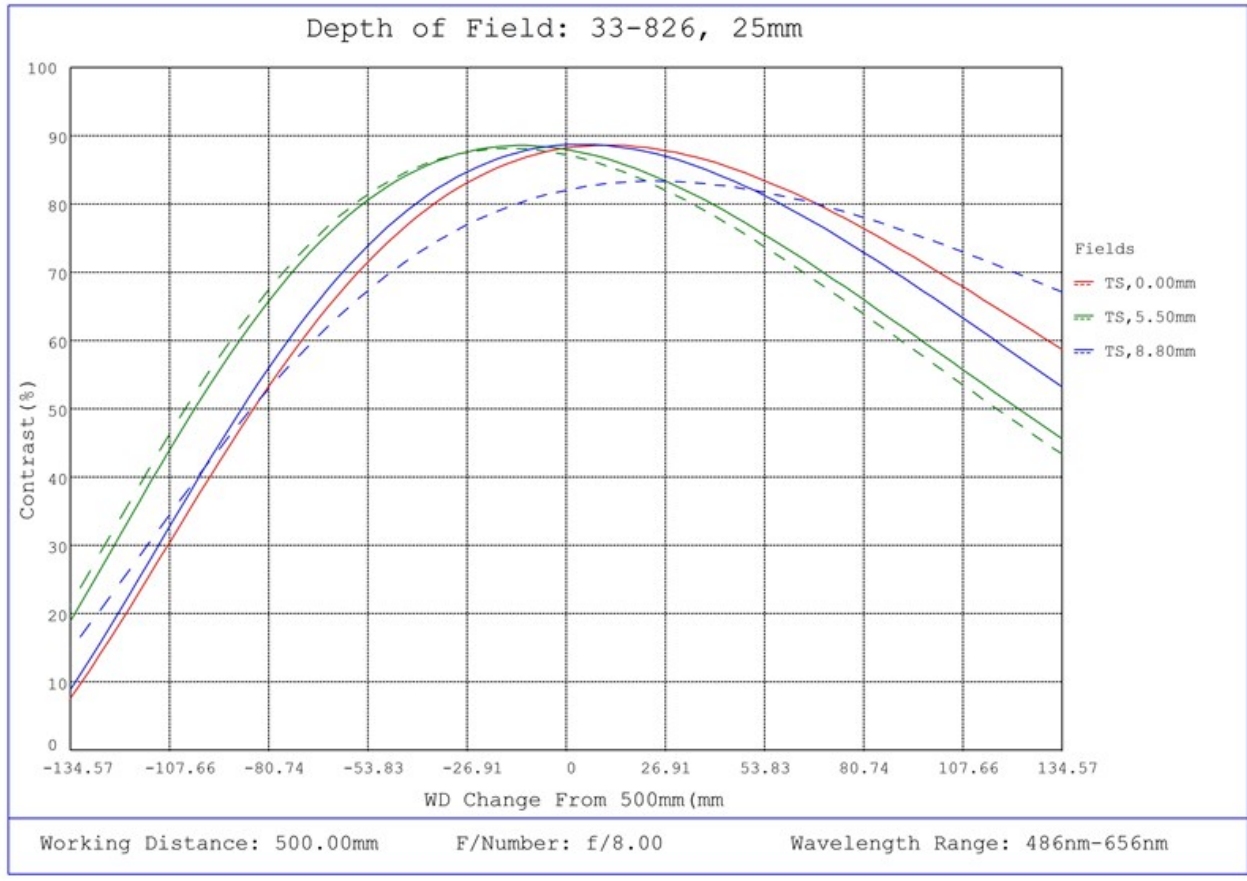

#33-826, 25mm f/8.0, HPI Series Fixed Focal Length Lens, Depth of Field Plot, 500mm Working Distance, f8

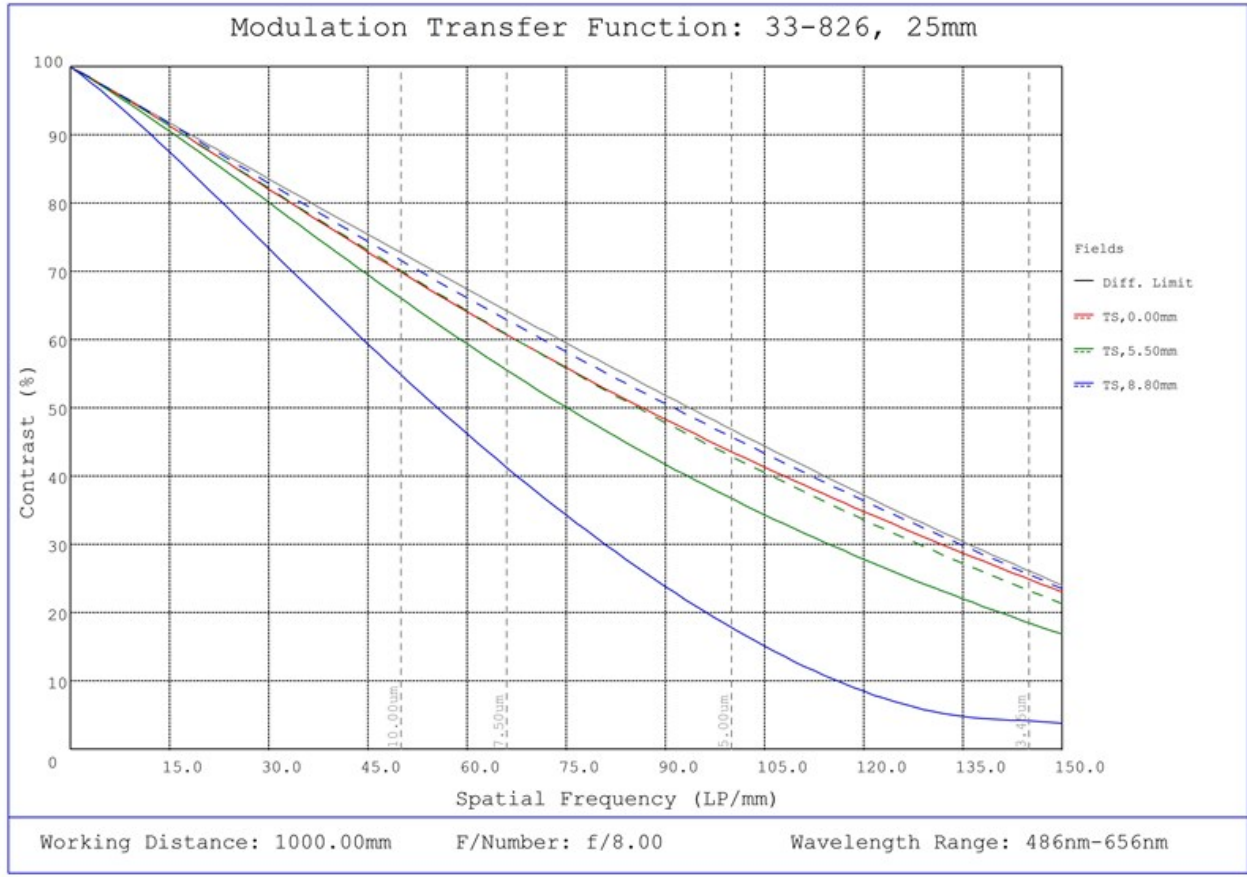

#33-826, 25mm f/8.0, HPi Series Fixed Focal Length Lens, Modulated Transfer Function (MTF) Plot, 1000mm Working Distance, f8



#33-826, 25mm f/8.0, HPI Series Fixed Focal Length Lens, Depth of Field Plot, 1000mm Working Distance, f8



September 23, 2023

To Whom It May Concern,

This document certifies that the product stated below has been reviewed as requested by Edmund Optics:

<i>Stock No.</i>	<i>Description</i>
33-826	25mm f/8.0, HPI Series Fixed Focal Length Lens

This item is EU RoHS (2011/65/EU) compliant without the use of exemptions.

This certification means that:

- EO's suppliers have confirmed the material composition of this product.
- EO has implemented rigorous procedures to document this compliance.
- The information provided may, or may not, be based upon actual test data, or on information from our Vendors, Raw Material Suppliers or Subcontractors.



Jay Budd, Director of Corporate Compliance
September 23, 2023

Edmund Optics Inc. - 101 E Gloucester Pike, Barrington, NJ 08007 | 1-800-363-1992 | Compliance@edmundoptics.com



September 23, 2023

<i>Stock No.</i>	<i>Description</i>
33-826	25mm f/8.0, HPI Series Fixed Focal Length Lens

Edmund Optics certifies that all articles included in this shipment are in compliance with the terms and conditions of this order. The company also certifies that the articles included in this shipment are in accordance to all agreed upon specifications and quality assurance provisions. Please call 1-800-363-1992 should any questions arise from this shipment.



Jeff Harvey- EVP of Operations

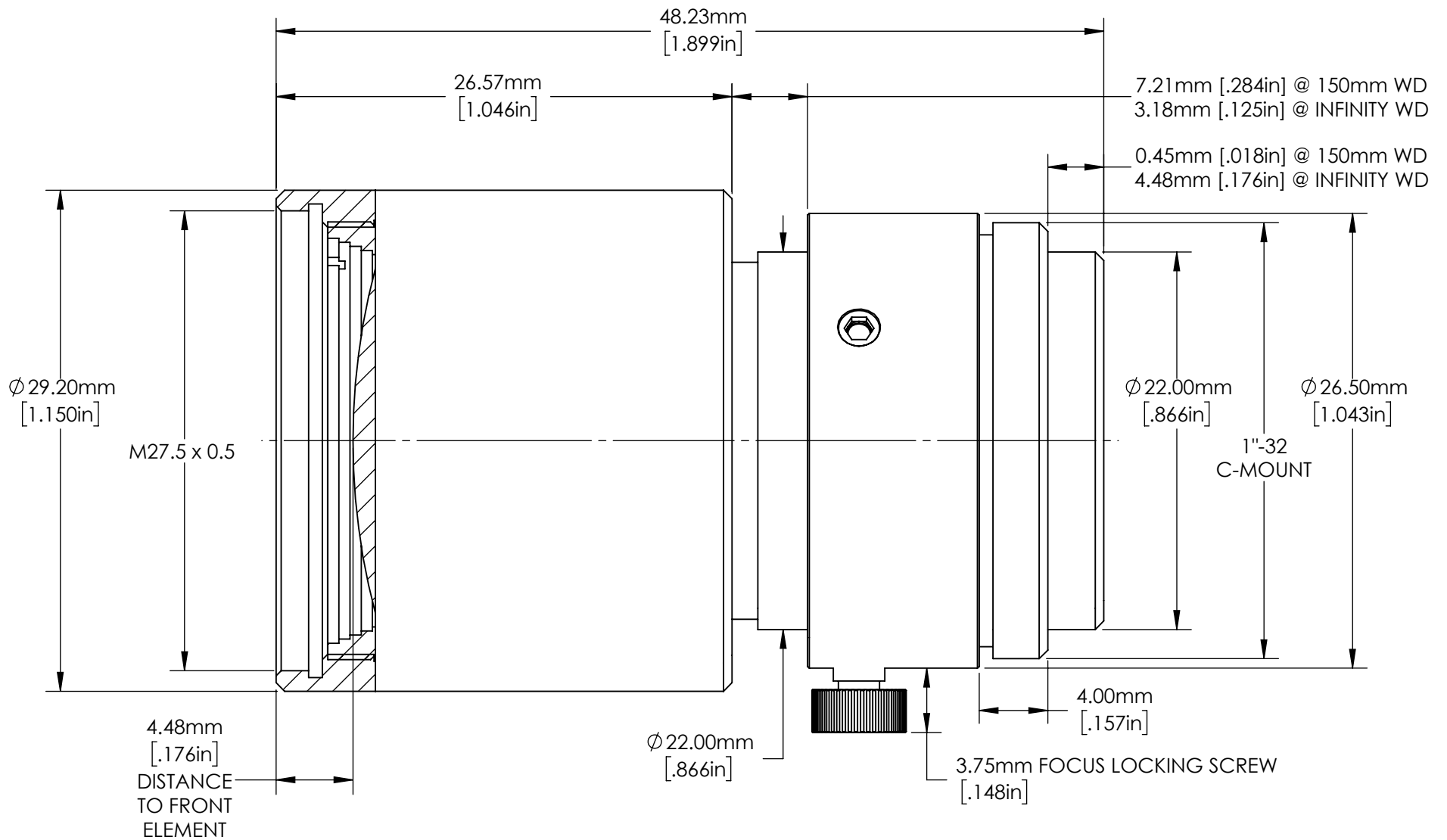

SPECIFICATIONS SUBJECT TO CHANGE WITHOUT NOTICE
 DIMENSIONS ARE FOR REFERENCE ONLY

EO® Edmund Optics®

**FOR INFORMATION ONLY:
 DO NOT MANUFACTURE
 PARTS TO THIS DRAWING**

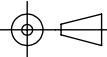
THIRD ANGLE PROJECTION 		TITLE	HPi 25mm, f/8.0	
ALL DIMS IN	mm	DWG NO	33826	SHEET 1 OF 1