

# TECHSPEC® F-THETA SCANNING LENS

- Simplify Your Optical System and Reduce Overall Costs
- Focus Beam Energy to a Small Spot Size
- Optimize Spot Size Relative to Incident Beam Angle

F-Theta lens is designed to provide a flat field on the image plane. This is especially important in scanning and engraving applications where a high power laser and a set of rotating mirrors are used to scan across a given field.

The key advantages of the F-Theta Lens in scanning & engraving applications are:

- Using F-Theta lens help reduce optical components needed to provide a flat field at the image plane.
- Focusing beam energy to a small spot size, providing better resolution for scanning and printing applications and higher power density for engraving and welding applications.
- Power and resolution are consistent across the entire scan/print field.



TECHSPEC® F-Theta Lens

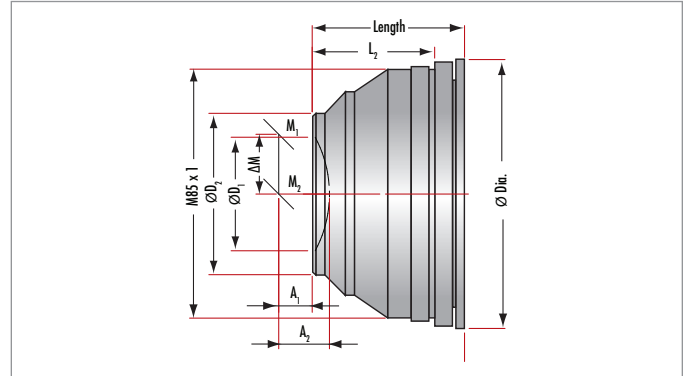

TECHSPEC® F-Theta Lens

DIMENSIONS								All Dimensions in mm	
Stock Number	Diameter	Length	L <sub>2</sub>	ΔM	A <sub>1</sub>	A <sub>2</sub>	D <sub>1</sub>	D <sub>2</sub>	
#63-313	87.6	50.4	47.6	20	10.14	20	40	55	
#63-310	90	50	40	20	7.54	12	34	52	
#63-311	90	48	38	20	10.82	17	40	54	
#59-959	90	49.5	41	20	7.54	15	34	50	
#59-960	90	52.5	40.6	16	7.86	12	26	47	
#59-961	90	51	41	20	11.23	17	38	54	
#59-962	110	64	20	30	10.52	16	44	70	
#59-956	90	24	20	18	18.08	20	48	60	
#59-957	90	24	20	18	16.99	20	48	60	
#59-958	90	24	20	18	16.34	20	48	60	

Stock No.	Wavelength	EFL (mm)	Scan Angle (°)	Scan Length (mm)	Scan Field (mm)	Entrance Pupil (mm)	Spot Size in (μm) (Center/Edge)	Working Distance (mm)	No. of Lenses	CW Damage Threshold	Pulsed Damage Threshold
#63-313	355nm	160	±25	160	112 x 112	6	17 / 19	206	4	100kW/cm <sup>2</sup>	1J/cm <sup>2</sup> @ 10ns
#63-310	532nm	100	±25	87	70 x 70	14	9 / 15	100	4	250kW/cm <sup>2</sup>	2.5J/cm <sup>2</sup> @ 10ns
#63-311	532nm	165	±25	173	115 x 115	14	17 / 20	186	4	250kW/cm <sup>2</sup>	2.5J/cm <sup>2</sup> @ 10ns
#59-959	1064nm	100	±28	100	70 x 70	10	16.8 / 18	112	3	1MW/cm <sup>2</sup>	5J/cm <sup>2</sup> @ 10ns
#59-960	1064nm	160	±26	142	100 x 100	10	24.5 / 26.5	181	3	1MW/cm <sup>2</sup>	5J/cm <sup>2</sup> @ 10ns
#59-961	1064nm	163	±28	159	112 x 112	10	24 / 24.6	187	3	1MW/cm <sup>2</sup>	5J/cm <sup>2</sup> @ 10ns
#59-962	1064nm	254	±28	248	175 x 175	10	34.3 / 38.6	296	3	1MW/cm <sup>2</sup>	5J/cm <sup>2</sup> @ 10ns
#59-956	10.6μm	100	±28	98	69 x 69	14	205 / 323.5	98	1	3kW/cm <sup>2</sup>	—
#59-957	10.6μm	150	±28	149	105 x 105	14	221.5 / 357	149	1	3kW/cm <sup>2</sup>	—
#59-958	10.6μm	200	±28	210	148 x 148	14	217.5 / 289	210	1	3kW/cm <sup>2</sup>	—

Contact us Today for A Volume or Custom Quote



800.363.1992 | www.edmundoptics.com

# TECHSPEC® F-THETA SCANNING LENS



## APPLICATION NOTE: F-THETA LENS THEORY

Minimizing distortion and forming an image on a flat plane are the main design criteria for scanning lenses. Typically singlet lenses form an image on a curved plane (Figure 1). Flat field scanning lenses are designed to compensate for this aberration and provide a flat surface scanning field. As a result, the output image size is proportional to the object size. However, such lenses provide scan length proportional to the tangent of the incident beam angle (Figure 2) and nonlinear to the angle itself requiring complicated control electronics. F-Theta lens is designed to address this problem and satisfy the linear relationship between the scan length and the incident beam angle (Figure 3).

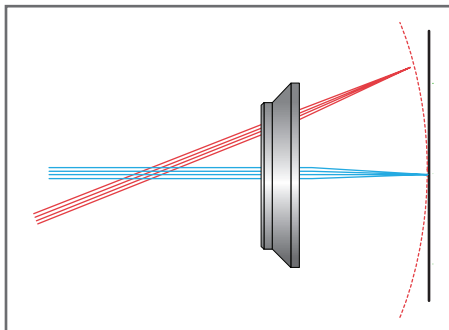

Figure 1 - Singlet

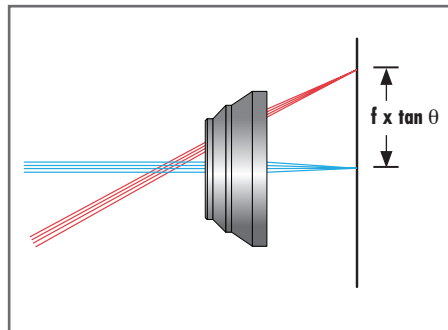

Figure 2 - Flat Field Scanning Lens

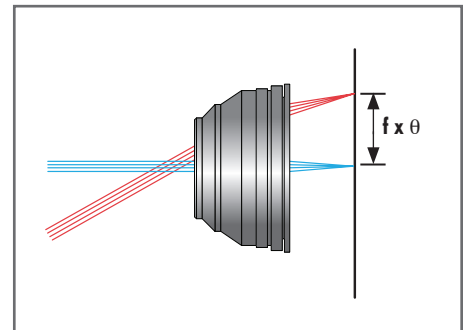

Figure 3 - F-Theta Scanning Lens

Another critical design aspect of an F-Theta lens is in the size and location of the entrance pupil. In order to accommodate the movement of the galvanometer mirror (typical of laser engraving systems), the entrance pupil must be located sufficiently far outside of the F-Theta lens itself. In a single mirror system, the mirror should be placed at the entrance pupil position, and the maximum beam diameter is equal to the entrance pupil diameter. In a 2-mirror system, the mirrors should be placed on either side of the entrance pupil position, with the distance between them minimized. The maximum beam diameter for this configuration is given by:

$$\text{Max Beam Diameter} = EP \left[ 1 - \frac{2\Delta M}{EP} \tan \Theta \right]$$

where EP is the entrance pupil diameter, ΔM is the distance between the mirrors, and Θ is half of the maximum beam deflection.

The two charts below show the maximum beam diameter for each of our F-Theta lenses, at various mirror separations. The first chart shows the maximum beam diameter for the full scanning angle, while the second chart shows the diameter for a smaller, 5° angle.

MIRROR SEPARATION - MAX SCAN ANGLE							
Stock No.	Mirror Separation in mm						
	0.00	5.00	10.00	15.00	20.00	30.00	40.00
#63313	6.00	1.34	N/A	N/A	N/A	N/A	N/A
#63310	14.00	9.34	4.67	0.01	N/A	N/A	N/A
#63311	14.00	9.34	4.67	0.01	N/A	N/A	N/A
#59959	10.00	4.68	N/A	N/A	N/A	N/A	N/A
#59960	10.00	5.12	0.25	N/A	N/A	N/A	N/A
#59961	10.00	4.68	N/A	N/A	N/A	N/A	N/A
#59962	10.00	4.68	N/A	N/A	N/A	N/A	N/A
#59956	14.00	8.68	3.37	N/A	N/A	N/A	N/A
#59957	14.00	8.68	3.37	N/A	N/A	N/A	N/A
#59958	14.00	8.68	3.37	N/A	N/A	N/A	N/A

MIRROR SEPARATION - 5° SCAN ANGLE							
Stock No.	Mirror Separation in mm						
	0.00	5.00	10.00	15.00	20.00	30.00	40.00
#63313	6.00	5.56	5.13	4.69	4.25	3.38	2.51
#63310	14.00	13.56	13.13	12.69	12.25	11.38	10.51
#63311	14.00	13.56	13.13	12.69	12.25	11.38	10.51
#59959	10.00	9.56	9.13	8.69	8.25	7.38	6.51
#59960	10.00	9.56	9.13	8.69	8.25	7.38	6.51
#59961	10.00	9.56	9.13	8.69	8.25	7.38	6.51
#59962	10.00	9.56	9.13	8.69	8.25	7.38	6.51
#59956	14.00	13.56	13.13	12.69	12.25	11.38	10.51
#59957	14.00	13.56	13.13	12.69	12.25	11.38	10.51
#59958	14.00	13.56	13.13	12.69	12.25	11.38	10.51

To ensure a minimum focused beam diameter, the diameter of the entrance pupil should be well matched with the diameter of the incoming laser beam. When the beam diameter of the laser is small in comparison to the entrance pupil of the F-Theta lens, a well designed Beam Expander, such as our TECHSPEC® Laser Beam Expander, should be considered.

Contact us Today for A Volume or Custom Quote



800.363.1992 | www.edmundoptics.com